

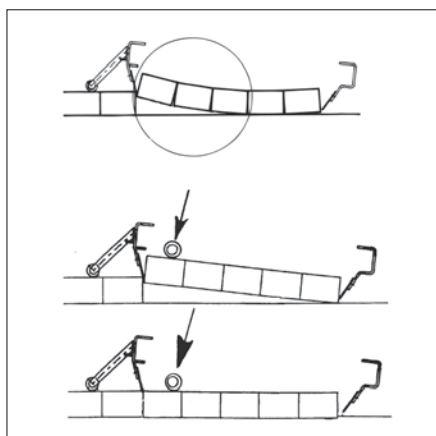

HVZ-UNI-II for VM-X/301/401/203/204



top: without ADV, bottom: with ADV

Hydraulic Installation Clamp HVZ-UNI-II

The new HVZ-UNI-II is more universal in use, more robust in design and more easy to adjust this device incorporates the experience of 2 decades in mechanical installation.

It can be used in conjunction with the laying machine VM-X/301/401/203/204 as well as other carriers which provide two hydraulic circuits to operate the clamp. The main and side clamps are controlled directly from the carrier.

- Setting of the main and side clamping width made easy without tools by using scale pointers.
- The side clamping arms swing up completely in order to allow laying close to a wall sideways without any gap.
- The powerful side clamp achieves easy shifting of pavers into the running bond.
- Gripping depths and height of the support wheels can be adjusted without tools easy and quickly.
- Pushing-off technology ADV guarantees installation complying with the regulations: During the laying process the individual pavers creep apart by approx. 0.5 – 1 mm (in addition to the spacer bars). This joint distance must not be eliminated by hammering!
- Because the pavers can not rock during the laying process, time consuming readjustment is avoided.
- Pushing off device ADV as a standard feature integrated.
- 2 C-Profiles 760 mm long and 10 Positioning Adapters to shift pavers by 100 mm.
- Low deadweight.
- Main gripping width can be set much more easily via a spindle with integrated spring assembly instead of the previous chain centring method.
- Significantly increased displacement force for problem-free movement into the running bond (3 x greater than with the HVZ-UNI).
- New suspension – enabling the clamp to hang with less movement.
- Durable surface protection by galvanizing.

Type	Length of Gripper mm (in)	Inside Height mm (in)	Dead Weight kg (lbs)	Hydr. Volumetric Flow l/min (gpm)	Hydr. Backflow Pressure, max. bar (psi)	Hydraulic Connection Pressure bar (psi)	Opening Width Main Gripper mm (in)	Opening Width Side Gripper mm (in)	Working Load Limit/ WLL kg (lbs)	Order-Number
HVZ-UNI-II for VM-X/301/203/204	1,200 (47.24)	70 (2.76)	225 (496)	15 – 75 (3.96 – 19.82)	20 (290.08)	200 – 320 (2,901 – 4,641)	580 – 1,260 (22.83 – 49.61)	960 – 1,440 (37.80 – 56.69)	400 (882)	51400036
HVZ-UNI-II for VM-401	1,200 (47.24)	70 (2.76)	226.5 (499)	15 – 75 (3.96 – 19.82)	20 (290.08)	200 – 320 (2,901 – 4,641)	580 – 1,260 (22.83 – 49.61)	960 – 1,440 (37.80 – 56.69)	400 (882)	51400037

Accessories:

Type	Description	Dead Weight kg (lbs)	Order-Number
HVZ-UNI-II-PEA	Set of PE supports for height adjustment	10.5 (23)	41400986

011223 Technical data contained in this catalogue can be modified without prior notice in the interest of progress. Illustrations are exemplary and non-binding. No liability accepted for any misprints, mistakes and errors.